

PIPE SIZE (NOM)	ITEM NUMBER	BAG SIZE	A IN. / MM	B IN. / MM	C IN. / MM	D IN. / MM	E IN. / MM	F IN. / MM	WEIGHT LBS / KGS
2 (50.8mm)	F3AVEB00114	01	22 / 559	7-11/16 / 195	18-3/4 / 476	5-3/8 / 136	37 / 940	13 / 330	25 / 11.3

REVISIONS

REV	DESCRIPTION	BY	ECO	DATE
B	UPDATED DRAWING	FJM	0087052	07/03/13

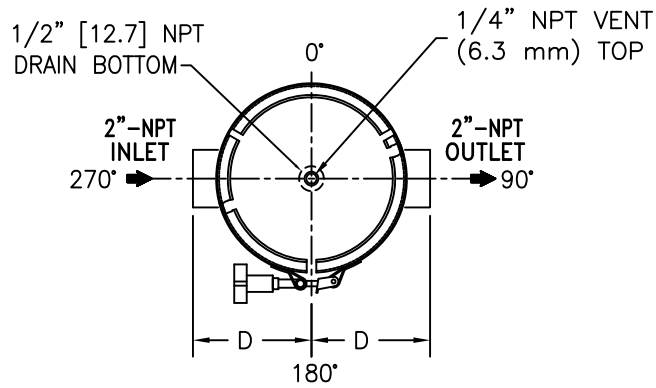

NO.	PART NAME	MATERIAL
1	BODY	316 STAINLESS STEEL
2	RESTRAINER BASKET 01 SIZE P/N L0001752	316 STAINLESS STEEL
3	ADAPTOR O-RING P/N 811441	BUNA-N
4	BAG HOLD DOWN	316 STAINLESS STEEL
5	O-RING P/N 811441	BUNA-N
6	COVER	316 STAINLESS STEEL
7	V-CLAMP	STAINLESS STEEL
8	ADAPTOR PLATE	STAINLESS STEEL

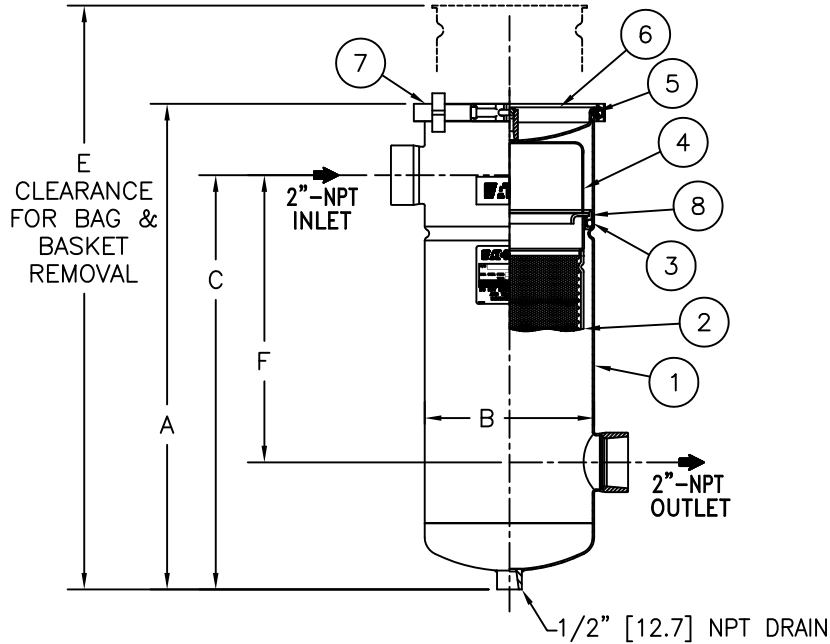

NOTES:

- INLET/OUTLET "NPT" THREADED CONNECTIONS PER ANSI B1.20.1
- MAWP: 100 PSI @ 250 °F (6.8 BAR @ 121.1 °C)
- DIMENSIONS SHOWN IN [] ARE IN MILLIMETERS AND FOR REFERENCE ONLY. ACCEPTANCE OF THIS PART WILL BE BASED ON "INCH" UNITS & TOLERANCES ONLY.

VESSEL CODE: EBF-0101-AB07-020N-NI-B-NNS

DRAWN BY	FJM	EATON EATON FILTRATION, LLC DESIGN CENTER TINTON FALLS, NEW JERSEY, USA • PORTAGE, MICHIGAN, USA
SCALE	AS DRAWN	
RESTRICTION	RESTRICTION	TITLE
SHEET	1 OF 1	ECOLINE (EBF-0101) FILTER VESSEL 2" NPT THREADED CONNECTIONS IN-LINE SS-316 W/BUNA O-RINGS
PROJECTION	THIRD ANGLE	DATE
		01/22/04
		SIZE
		A
		DWG FILENAME
		SDI-07516
		REV
		B

TOLERANCES (UNLESS OTHERWISE SPECIFIED)	
DECIMAL:	X ± .030
	.XX ± .010
	.XXX ± .005
FRACTIONAL:	± 1/16
NOZZLE Ø TO FLOOR:	1/8" < 4' > 1/4"
FACE TO FACE:	1/8" < 4' > 1/4"
ANGULAR:	± 1'
FLANGES (H/V):	± 1/2
VESSEL OVERALL HT:	1"

REVIEWED FOR CLASSIFICATION PER PR-4
 CRITICAL SIGNIFICANT

CUSTOMER INFO	
NAME	
P.O. NO.	
S.O. NO.	
QUANTITY	
PART NO.	F3AVEB00114

EATON CORPORATION - CONFIDENTIAL AND PROPRIETARY NOTICE TO PERSONS RECEIVING THIS DRAWING AND/OR TECHNICAL INFORMATION
 THIS DOCUMENT, INCLUDING THE DRAWING AND INFORMATION CONTAINED THEREON IS CONFIDENTIAL AND IS THE EXCLUSIVE PROPERTY OF EATON AT ANY TIME. BY TAKING THE POSSESSION OF THIS DOCUMENT THE RECIPIENT ACKNOWLEDGES AND AGREES THAT THIS DOCUMENT CANNOT BE USED IN ANY MANNER ADVERSE TO THE INTEREST OF EATON AND THAT NO PORTION OF THIS DRAWING MAY BE COPIED OR OTHERWISE REPRODUCED WITHOUT THE PRIOR WRITTEN CONSENT OF EATON, IN THE CASE OF CONFLICT CONTRACTUAL PROVISIONS, THIS NOTICE SHALL GOVERN THE STATUS OF THIS DOCUMENT.
 2013 EATON CORPORATION - ALL RIGHTS RESERVED.

PIPE SIZE (NOM)	ITEM NUMBER	BAG SIZE	A IN. / MM	B IN. / MM	C IN. / MM	D IN. / MM	E IN. / MM	F IN. / MM	WEIGHT LBS / KGS
2 (50.8mm)	F3AVEB00100	02	37-9/16 / 954	7-11/16 / 195	34-5/16 / 872	5-3/8 / 136	67-1/2 / 1714	28-9/16 / 725	38 / 17.2

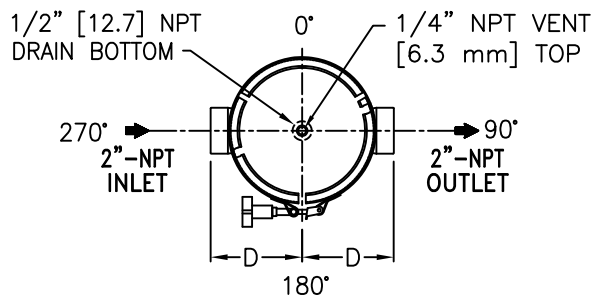

REVISIONS				
REV	DESCRIPTION	BY	ECO	DATE
C	UPDATED DRAWING	FJM	0087052	07/03/13

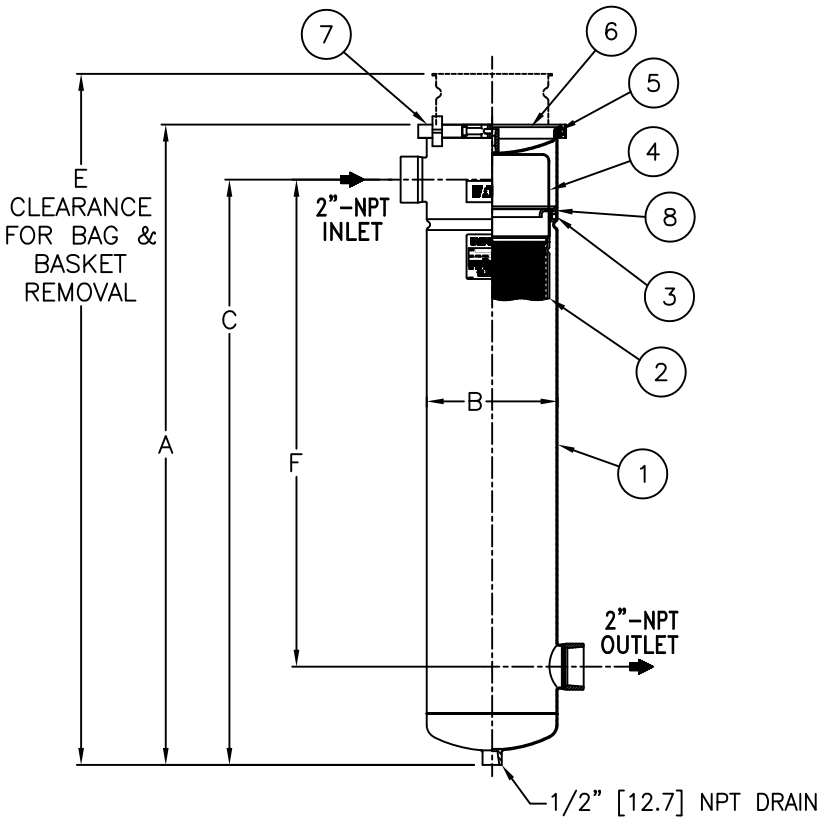

NO.	PART NAME	MATERIAL
1	BODY	316 STAINLESS STEEL
2	RESTRAINER BASKET 02 SIZE P/N L0001753	316 STAINLESS STEEL
3	ADAPTOR O-RING P/N 811441	BUNA-N
4	BAG HOLD DOWN	316 STAINLESS STEEL
5	O-RING P/N 811441	BUNA-N
6	COVER	316 STAINLESS STEEL
7	V-CLAMP	STAINLESS STEEL
8	ADAPTOR PLATE	STAINLESS STEEL

- NOTES:**
- INLET/OUTLET "NPT" THREADED CONNECTIONS PER ANSI B1.20.1
 - MAWP: 100 PSI @ 250 °F
(6.8 BAR @ 121.1 °C)
 - DIMENSIONS SHOWN IN [] ARE IN MILLIMETERS AND FOR REFERENCE ONLY. ACCEPTANCE OF THIS PART WILL BE BASED ON "INCH" UNITS & TOLERANCES ONLY.

TOLERANCES (UNLESS OTHERWISE SPECIFIED)	
DECIMAL:	.X ± .030
	.XX ± .010
	.XXX ± .005
FRACTIONAL:	± 1/16
NOZZLE Ø TO FLOOR:	1/8" < 4' > 1/4"
FACE TO FACE:	1/8" < 4' > 1/4"
ANGULAR:	± 1'
FLANGES (H/V):	± 1/2"
VESSEL OVERALL HT:	1"

REVIEWED FOR CLASSIFICATION PER PR-4
 CRITICAL SIGNIFICANT

CUSTOMER INFO	
NAME	
P.O. NO.	
S.O. NO.	
QUANTITY	
PART NO.	F3AVEB00100

DRAWN BY FJM		VESEL CODE: EBF-0102-AB07-020N-NI-B-NNS	
SCALE AS DRAWN		EATON FILTRATION, LLC DESIGN CENTER TINTON FALLS, NEW JERSEY, USA • PORTAGE, MICHIGAN, USA	
RESTRICTION RESTRICTION		TITLE ECOLINE (EBF-0102) FILTER VESSEL 2" NPT THREADED CONNECTIONS IN-LINE SS-316 W/BUNA O-RINGS	
SHEET 1 OF 1		DATE 06/03/04	SIZE A
PROJECTION THIRD ANGLE		DWG FILENAME EBF11XS-S0	REV C
<small>EATON CORPORATION - CONFIDENTIAL AND PROPRIETARY NOTICE TO PERSONS RECEIVING THIS DRAWING AND/OR TECHNICAL INFORMATION THIS DOCUMENT, INCLUDING THE DRAWING AND INFORMATION CONTAINED THEREON IS CONFIDENTIAL AND IS THE EXCLUSIVE PROPERTY OF EATON AT ANY TIME. BY TAKING THE POSSESSION OF THIS DOCUMENT THE RECIPIENT ACKNOWLEDGES AND AGREES THAT THIS DOCUMENT CANNOT BE USED IN ANY MANNER ADVERSE TO THE INTEREST OF EATON AND THAT NO PORTION OF THIS DRAWING MAY BE COPIED OR OTHERWISE REPRODUCED WITHOUT THE PRIOR WRITTEN CONSENT OF EATON, IN THE CASE OF CONFLICT CONTRACTUAL PROVISIONS, THIS NOTICE SHALL GOVERN THE STATUS OF THIS DOCUMENT. 2013 EATON CORPORATION - ALL RIGHTS RESERVED.</small>			